

INTERNATIONAL MARITIME ORGANIZATION
4 ALBERT EMBANKMENT
LONDON SE1 7SR

Telephone: 020 7735 7611
Fax: 020 7587 3210
Telex: 23588 IMOLDN G



E

Ref. T2-NAVSEC/2.6.1

MSC/Circ.1080
6 June 2003

**ADOPTION OF AMENDMENTS TO THE INTERNATIONAL
AERONAUTICAL AND MARITIME SEARCH
AND RESCUE (IAMSAR) MANUAL**

1 The Maritime Safety Committee (MSC), at its seventy-seventh session, (28 May to 6 June 2003), having been informed that the International Civil Aviation Organization (ICAO) had approved the amendments to the IAMSAR Manual prepared by the Joint ICAO/IMO Working Group on Harmonization of Aeronautical and Maritime Search and Rescue, and that they had been endorsed by the Sub-Committee on Radiocommunications and Search and Rescue (COMSAR) at its seventh session (13 to 17 January 2003), adopted the annexed amendments in accordance with the procedure laid down in resolution A.894(21).

2 MSC 77 decided that the amendments should enter into force on 1 July 2004.

ANNEX**SECTION 1****Proposed amendments to the IAMSAR Manual,
Volume I, paragraph 1.8, and Volume II, paragraph 6.1.2**

- 1 In sub-paragraph (a), 3rd line, after “coastal SAR installations”, add a comma and the following words: “including RCCs and RSCs as far as these centers are located in coastal areas and are used exclusively to co-ordinate search and rescue operations.”
- 2 Add a new sub-paragraph (c): “The above-mentioned coastal installations should, in time of armed conflict, display the distinctive emblem (red cross or red crescent), according to regulations issued by their competent authorities.”
- 3 Add a new sub-paragraph (d): “It is recommended that Parties to a conflict notify the other Parties with the name, description and locations (or area of activity) of their above-mentioned rescue craft and coastal installations in the area they are located.”

SECTION 2**Proposed amendments to the IAMSAR Manual
Volume I, Paragraph 2.3.4, and Volume II, paragraph 3.4.4**

- 1 Volume I: Add at the end of paragraph 2.3.4, as follows:

“A Coastal State may have a MRCC but not be able to be provided with an ARCC. In such a case the SAR Manager should arrange a suitable organizational relationship to provide the MRCC with aeronautical advice. Advice may be available from aeronautical facilities close to hand, such as an aerodrome tower, an ARCC, a Flight Information Centre (FIC), or an area control centre (ACC).”
- 2 Volume II: Add to the bottom of paragraph 3.4.4, as follows:

“An MRCC may also request an ATS unit to provide the above information in the case of an aeronautical incident at sea. The MRCC should communicate first with a local ATS unit, such as an aerodrome tower. An ARCC, a Flight Information Centre (FIC) or an area control centre (ACC) may also have relevant information, or may be able to assist with investigations using aeronautical communications and resources.”

SECTION 3

Proposed amendments to the IAMSAR Manual, Volume III

Safety Precautions when approaching or leaving a helicopter

After the end of the paragraph on **Safety Preparations**, add a new paragraph on page 2-31 of Volume III

■ **Safety Precautions when approaching or leaving a helicopter**

- Do not approach or depart a helicopter UNLESS directed to do so by the pilot or crewman

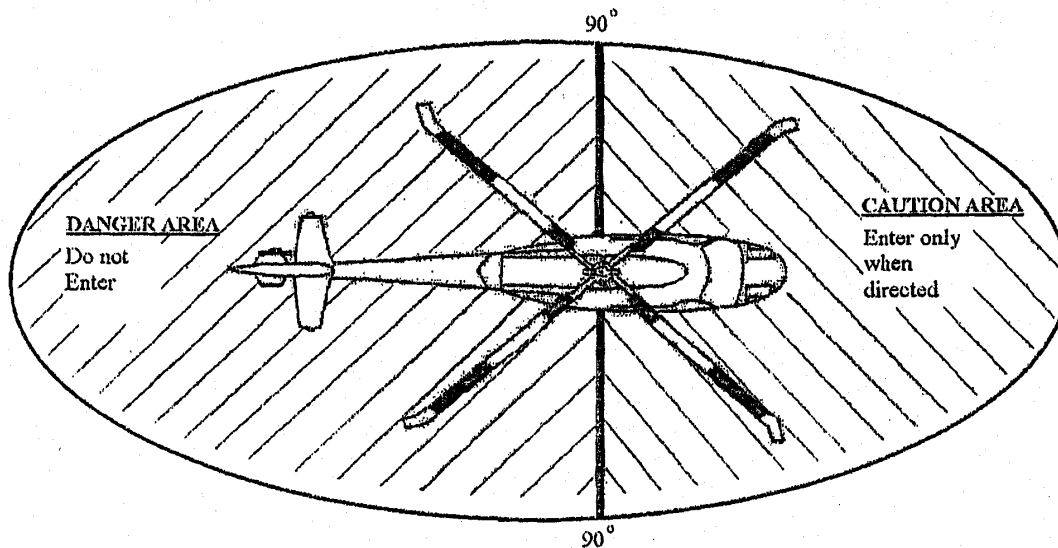

Generic Safety Illustration