



Ref. T4/4.01

MSC.1/Circ.1237
30 October 2007

**AMENDMENTS TO THE REVISED GUIDELINES FOR THE APPROVAL OF
EQUIVALENT WATER-BASED FIRE-EXTINGUISHING SYSTEMS FOR
MACHINERY SPACES AND CARGO PUMP-ROOMS (MSC/CIRC.1165)**

1 The Committee, at its eightieth session (11 to 20 May 2005), after having considered the proposal by the forty-ninth session of the Sub-Committee on Fire Protection regarding review on the Guidelines for the approval of equivalent water-based fire-extinguishing systems as referred to in SOLAS 74 for machinery spaces and cargo pump-rooms (MSC/Circ.668 as amended by MSC/Circ.728), approved Revised Guidelines for the approval of equivalent water-based fire-extinguishing systems for machinery spaces and cargo pump-rooms (MSC/Circ.1165).

2 The Sub-Committee on Fire Protection, at its fifty-first session (5 to 9 February 2007), reviewed the Revised Guidelines for the approval of equivalent water-based fire-extinguishing systems for machinery spaces and cargo pump-rooms (MSC/Circ.1165) and, acknowledging figures 1, 2 and 3 in the Revised Guidelines did not clearly illustrate the recommended fire test configurations and spray fire locations, revised the aforementioned figures accordingly to clearly show the specified test arrangements.

3 The Committee, at its eighty-third session (3 to 12 October 2007), after having considered the above proposal, approved amendments to figures 1, 2 and 3 of the Revised Guidelines for the approval of equivalent water-based fire-extinguishing systems for machinery spaces and cargo pump-rooms (MSC/Circ.1165), as set out in the annex.

4 Member Governments are invited to apply the amendments to the Revised Guidelines when approving equivalent water-based fire-extinguishing systems for machinery spaces and pump-rooms and bring them to the attention of ship designers, shipowners, equipment manufacturers, test laboratories and other parties concerned.

ANNEX

AMENDMENTS TO THE REVISED GUIDELINES FOR THE APPROVAL OF
EQUIVALENT WATER-BASED FIRE-EXTINGUISHING SYSTEMS FOR
MACHINERY SPACES AND CARGO PUMP-ROOMS (MSC/CIRC.1165)

1 The existing figures 1, 2 and 3 are replaced by the following figures 1, 2 and 3, respectively:

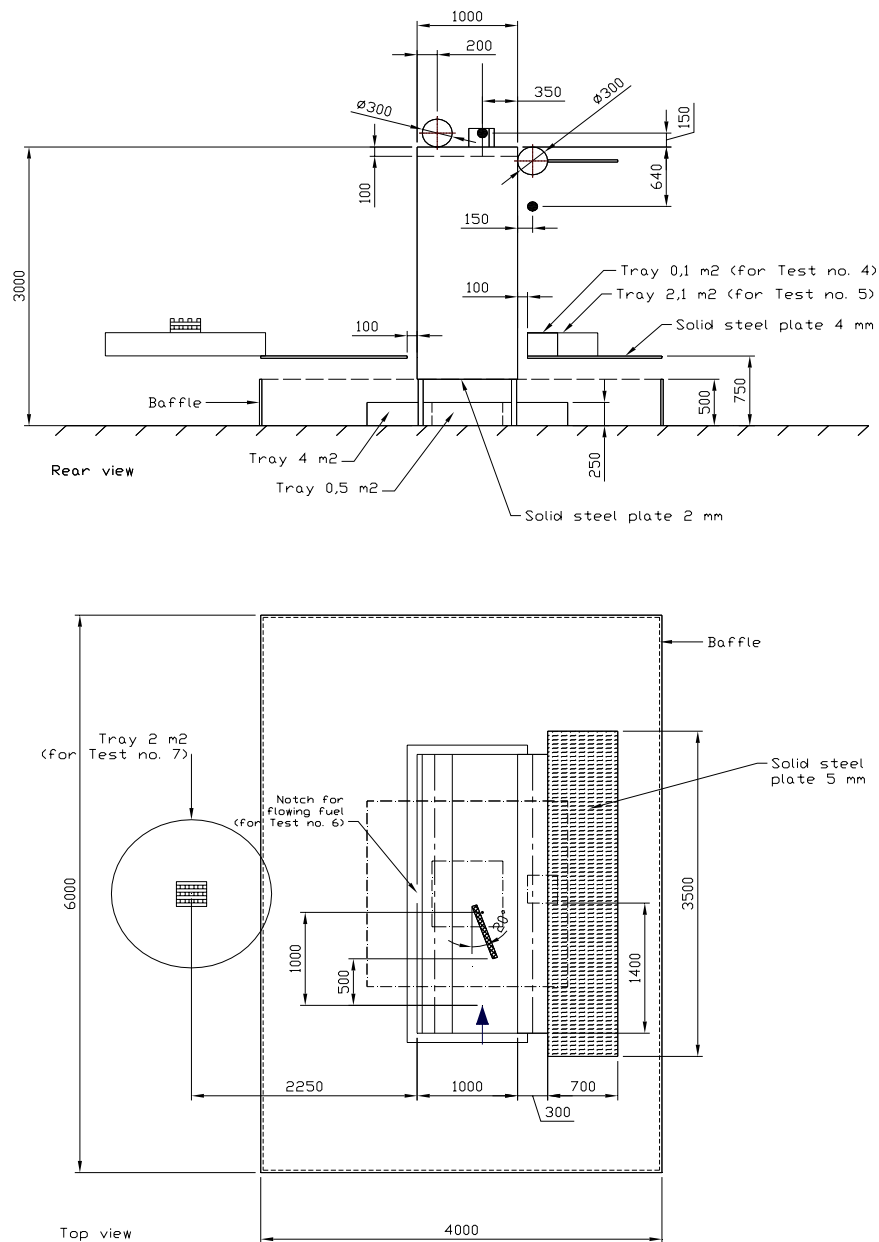

Figure 1

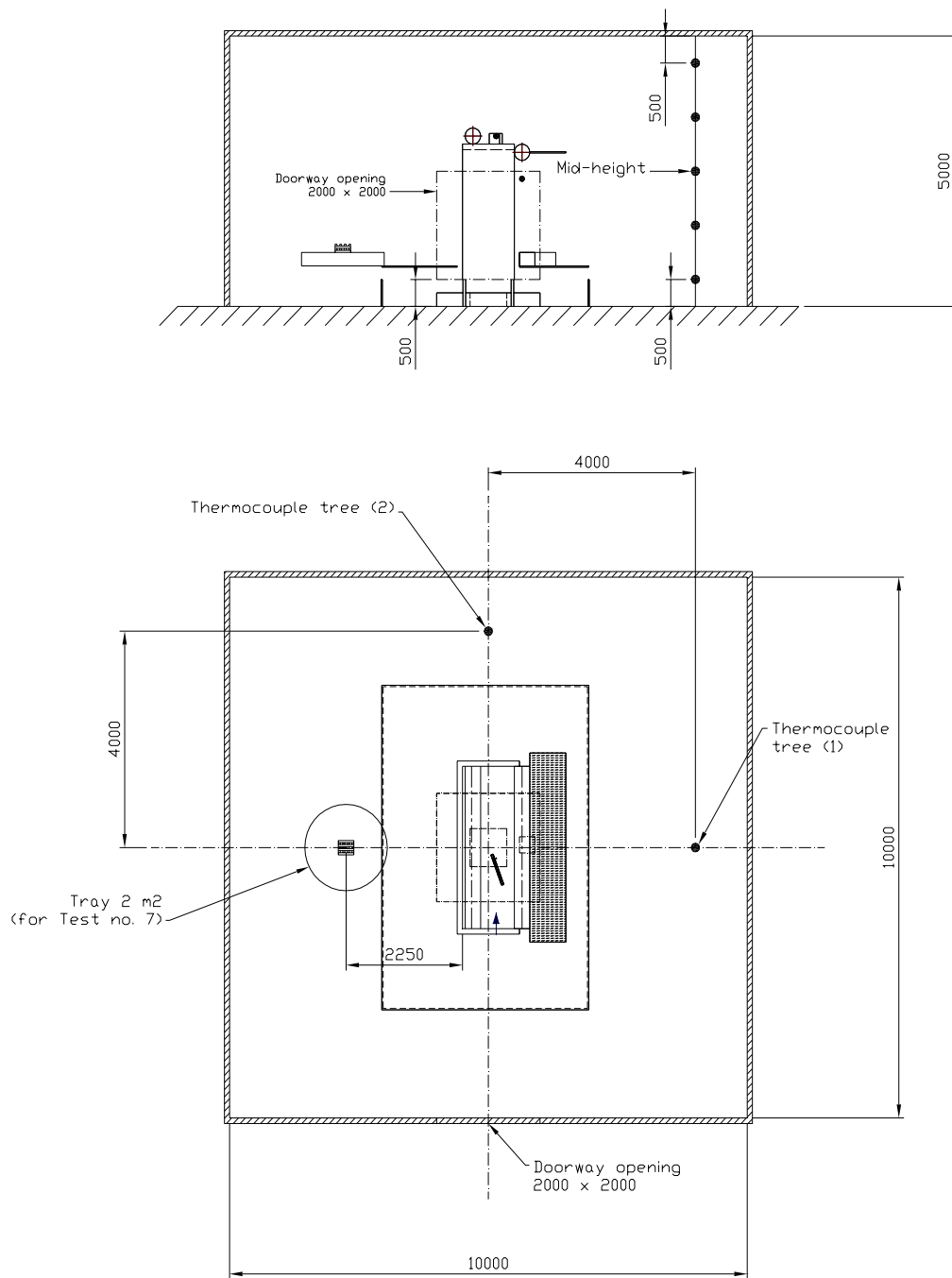

Figure 2

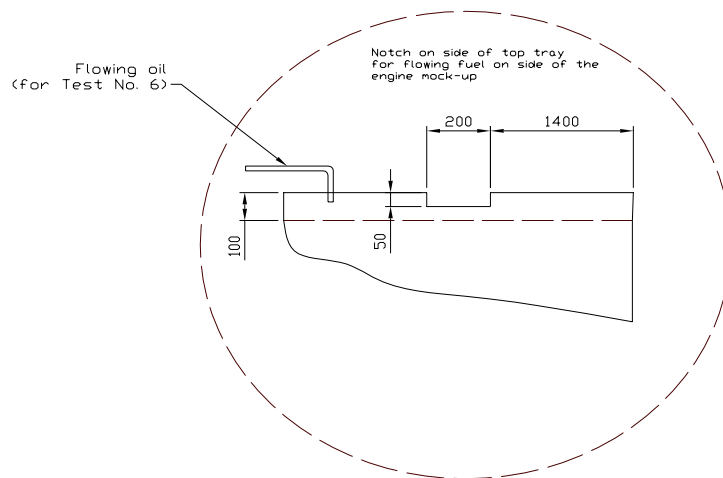
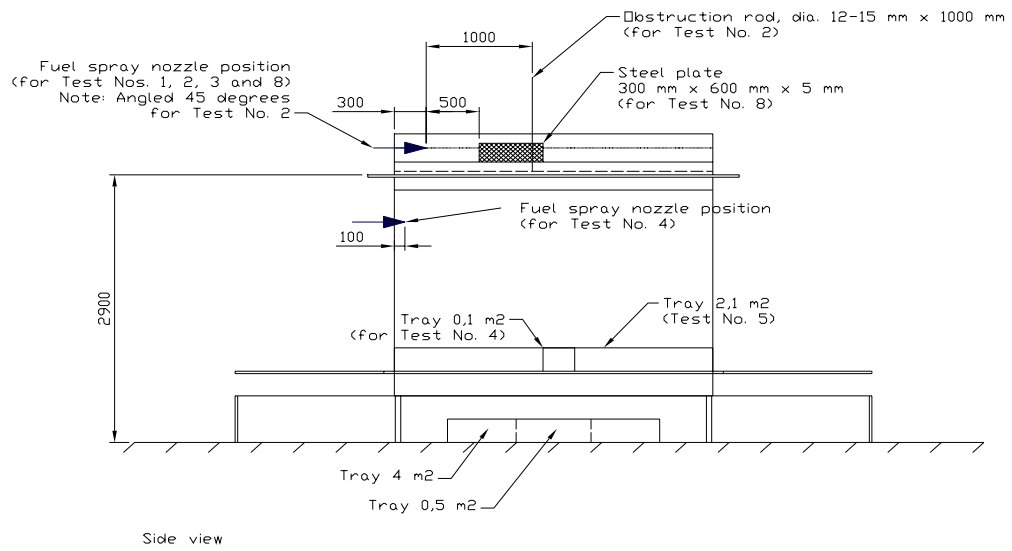

Figure 3